

**General information:**

EL500-2405 has been specifically developed to meet the DC powering requirements for telecommunications, industrial and marine applications. The unit has a 230Vac, power factor corrected single phase input with soft-start, and operates over a wide range of input voltage. The output is current limited, with short circuit protection. EL500-2405 is a high quality and reliable switch mode power supply with low weight, small mechanical dimensions and high efficiency. It is designed to work in parallel with a 24V battery, giving a no-break power supply for different electronic equipments such as fire alarm systems, intruder alarm, access control systems aso. EL500-2405 has relay contacts output (potential free) giving information about battery condition, mains and charger failure. Light emitting diodes indicates battery condition, mains/charger "OK", overload and fuse errors.



- **EL500-2405 key data:**

- **Output power (27,6V/5A)**
- **2 output circuits with fuses and LED's which illuminates by fuse break.**
- **All outputs are secured against overload, short circuit and over voltage.**
- **Potential free alarm output for main/charger fault.**
- **Potential free alarm output for battery failure.**
- **Separate input for battery connection to achieve a "No-Break distribution system"**
- **Built in battery test function, controlled automatically or externally.**
- **Automatic protection against deep discharging of the battery.**
- **Approved by NEMKO and marked with CE label.**





Battery supervision and battery protection

EL500-2405 has an automatic battery test procedure. The battery will be tested every 60 min. If the battery voltage falls below 22V, the LED marked BATTERY OK will be switched off.

This LED will illuminate again when battery voltage increases to 23,8V.

When mains disappear, the battery will supply current to the load and the LED will start flashing.

A battery test may be done manually by short circuiting the terminals marked BATTERY TEST a short time. During mains failure the battery will be discharged. In order to protect the battery from completely discharging and risk for destroying, the load will be disconnected when the battery voltage has fallen down to 19V. When the mains is back and the voltage has increased to 23,8V, the load will automatically be connected to the power supply again.



Supervising the Mains and the Charger

The LED marked MAINS/CHARGER OK illuminates when the charger supplies current. This LED will turn off when the charger stops supplying current.



Alarm outputs

EL500-2405 has separate outputs in order to send information about battery condition and mains/charger condition externally..

The relay contacts are potential free and withstand a current up to 2 Amps

Mains/Charger faults:

Relay contacts marked MAINS/ CHARGER FAULT C and NO is connected by mains/charger faults.

Relay contacts marked MAINS/ CHARGER FAULT C and NC is disconnected by mains/charger faults.

When these faults occur there is a time delay of 30 sec.before the relay contacts is activated.

This time delay is standard, but may be changed to 30 min by connecting the strap marked S1.

(See connecting diagram page 4)

Battery fault:

Relay contacts marked BATTERY FAULT C and NO is connected by battery fault.

Relay contacts marked BATTERY FAULT C and NC is disconnected by battery fault.

Protection against overload and short-circuiting:



The LED marked OVERLOAD illuminates when the current consumption exceeds the rated current of the rectifier.

The rectifier will limit the output current to max 5,5A and the output voltage decrease in order to maintain the output current constant without any danger for the power supply.

The charger is equipped with 2 separate outputs, each with a 5 amp fuse.

The basic purpose of these fuses are to protect the battery against irregular current draw.

Red LED`s on the front marked FUSE ERROR 1,2 illuminates when the respective fuses are broken. The fuses are marked in the same way (1,2)

The LED`s will only illuminate if a load is connected to the power supply.



Over voltage protection:

The Mains input is protected by a MOV (Metal oxide varistor) against transients and over voltage. In addition a common mode and a diff. mode coil is connected together with X and Y capacitor to line / earth in order to attain the EMC requirements.

On the secondary side of the power supply all inputs and outputs are equipped with tranzorb diodes to protect against static electricity or induced voltage transients from outside the cabinet through the cables.



Technical data:

Input:

Input voltage:	180 - 250VAC 47-63 Hz
Input power:	150W (On full load on all outputs)
Over voltage protection:	Yes, MOV (metal oxide varistor)
Input fuse:	20x5mm glass fuse 2A slow blow
Connections:	Screw terminals max 2,5mm ²

Output:

Voltage:	27,6VDC +/- 100mV (Adjustable +/- 2,5V)
Current max:	5A continuously.
Power max:	138W
Voltage accuracy:	<1% by 0-100% load and/or input voltage variations from 180 to 250VAC
Output circuits :	2 pcs. Each with a 20x5mm glass fuse 5A slow blow
Battery input:	1 pcs. 24V
Short circuit protected	Yes.
Protected against overload:	Yes, Current limiting at 5,5Amp +/- 0,5Amp
Over voltage protection:	Yes, level : 30V +/- 0,5V
Ripple and noise on output:	<100mV p-p DC-30MHz, measured with a noise probe direct on the output connectors.
All connections:	Screw terminals max 2,5mm ²

Information output / Input:

Mains/charger faults	Potential free relay contacts no,nc,c max load 2 Amp
Battery fault:	Potential free relay contacts no,nc,c max load 2 Amp
Battery test input :	Active low , Internal pull up with 10Kohm
Connections:	Screw terminals max 2,5mm ²

General data:

Battery connections:	Screw terminals max 2,5mm ²
Switch-frequency:	48kHz
Efficiency:	>88%, by full load.
Soft start:	Yes
Mounting:	4 pcs. Holes for screws
Weight:	800g
Dimensions:	L*W*H: 205mm*107mm*69mm
Density:	IP 20
Cooling:	Free air passage
Ambient temperature:	0 - +40°C

Approvals:

Meet the requirements in the safety standard EN60950.
 Meet the requirements in RFI/EMI standard EN55022 level B
 EL500-2405 is approved by NEMKO and marked with a CE label.



Installation and Connection

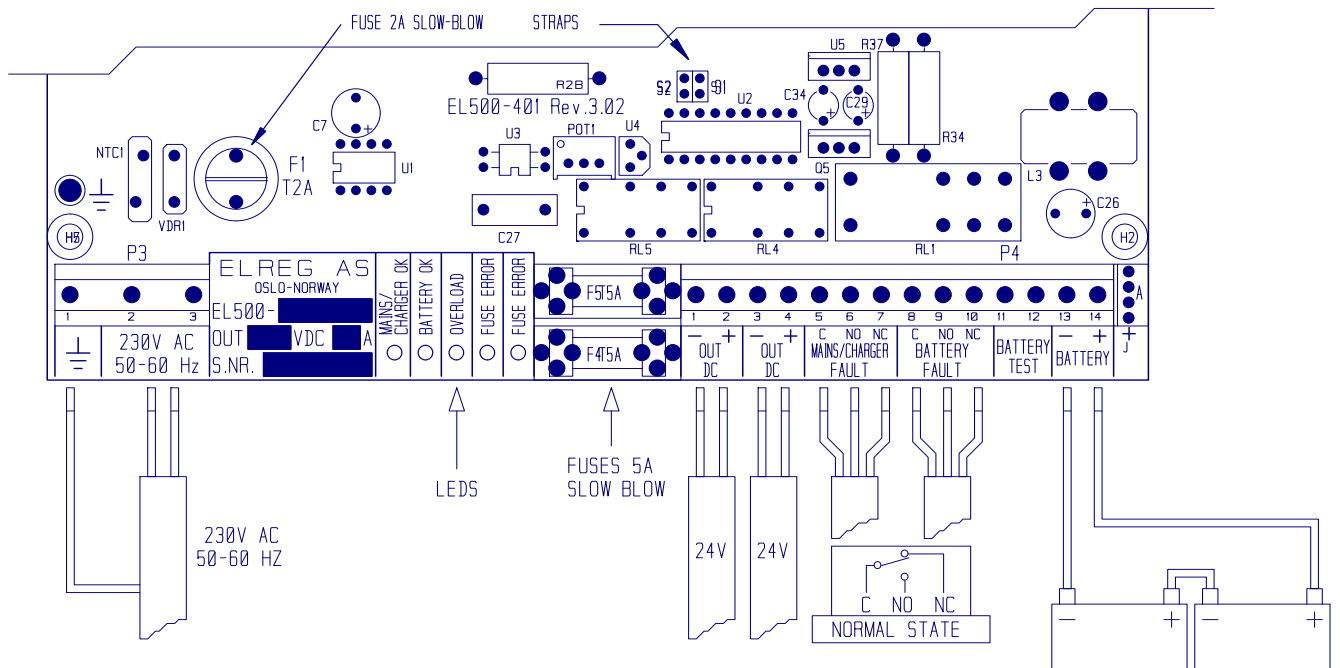



TEST REPORT

Model:

EL500-2405

Serial no:.....

- **Output voltage adjustment**
- **Current limiting function tested**
- **Switching frequency tested**
- **Measured noise and ripple**
- **Battery control function tested**
- **Mains fault function tested**
- **Deapdischarge protection tested**
- **Fuses tested**
- **Earth connection / Isolation test acc.to EN50116**

Tested by:

Date:.....

Sign:.....